

Schutzvermerk nach DIN 34 bzw. ISO 16016 beachten

		Maßstab		Gewicht		Allgemeintoleranz		Oberflächenangaben	
		1:1		fertig Roh		nach		nach	
				?? ??		DIN ISO 2768 m		DIN ISO 1302	
		2000		Datum		Name		Benennung	
		Bearb.		14.03.07		gb		Frontplatte 1 HE Breite 444	
		Gepr.							
								Blatt:	
								2	
								Bl.	
								5	
								Dateiname	
								MG44414S.CATDrawing	
								Zeichnungs-Nr.	
								MG13002.CATPart	
								Dateiname	
								MG44414S.CATDrawing	
								Daub CNC Technik GmbH u. Co.KG	
								Am Dassenborn 20	
								57482 Wenden	
								Tel.: +49(2762)97 92 75	
								Fax: +49(2762)97 93 75	
								e-mail: mail@19zoll.com	
								Internet:www.19zoll.com	
								AUS- gabe	
								Änderung	
								Datum	
								Name	

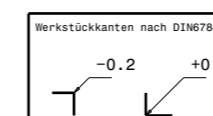

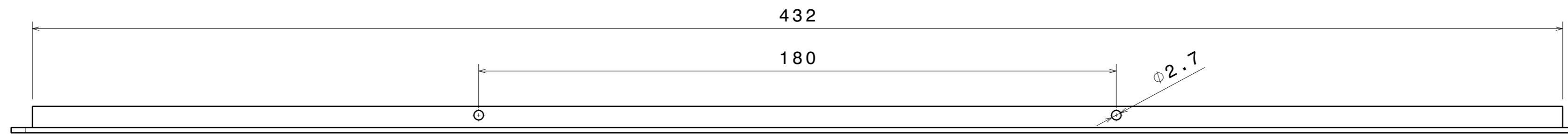
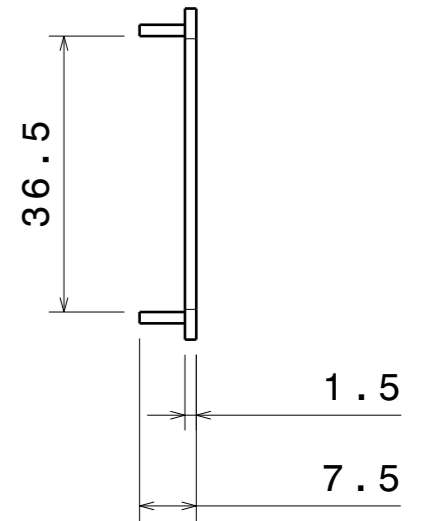
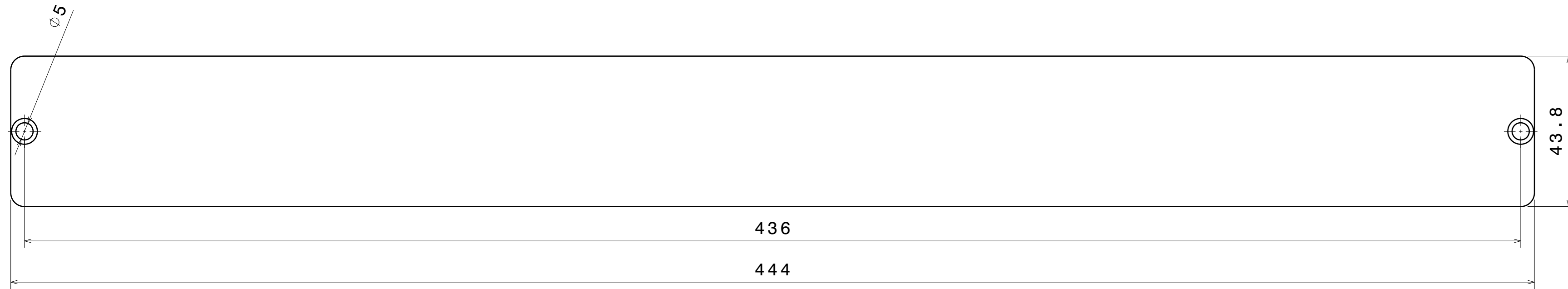

Schutzvermerk nach DIN 34 bzw. ISO 16016 beachten

Maßstab		Gewicht		Allgemeintoleranz		Oberflächenangaben	
1:1		fertig Roh		nach		nach	
		?? ??		DIN ISO 2768 m		DIN ISO 1302	
2000		Datum		Name		Benennung	
Bearb.		14.03.07		gb		Frontplatte 1 HE Breite 444	
Gepr.							
Werkstückkanten nach DIN 6784		-0.2		+0.2		Blatt:	
AUS-		Änderung		Datum		Name	
gabe						3	
						Bl.	
						5	
Daub CNC Technik GmbH u. Co.KG		Am Dassenborn 20		7482 Wenden		Zeichnungs-Nr.	
Tel.: +49(2762)97 92 75		Fax: +49(2762)97 93 75		e-mail: mail@19zoll.com		MG11002.CATPart	
Internet:www.19zoll.com						Dateiname	
						MG44414S.CATDrawing	



